



# FUSE PANEL

## Technical Practice

### FDP 1010

10/10 GMT  
NEBS Level 3 Certified

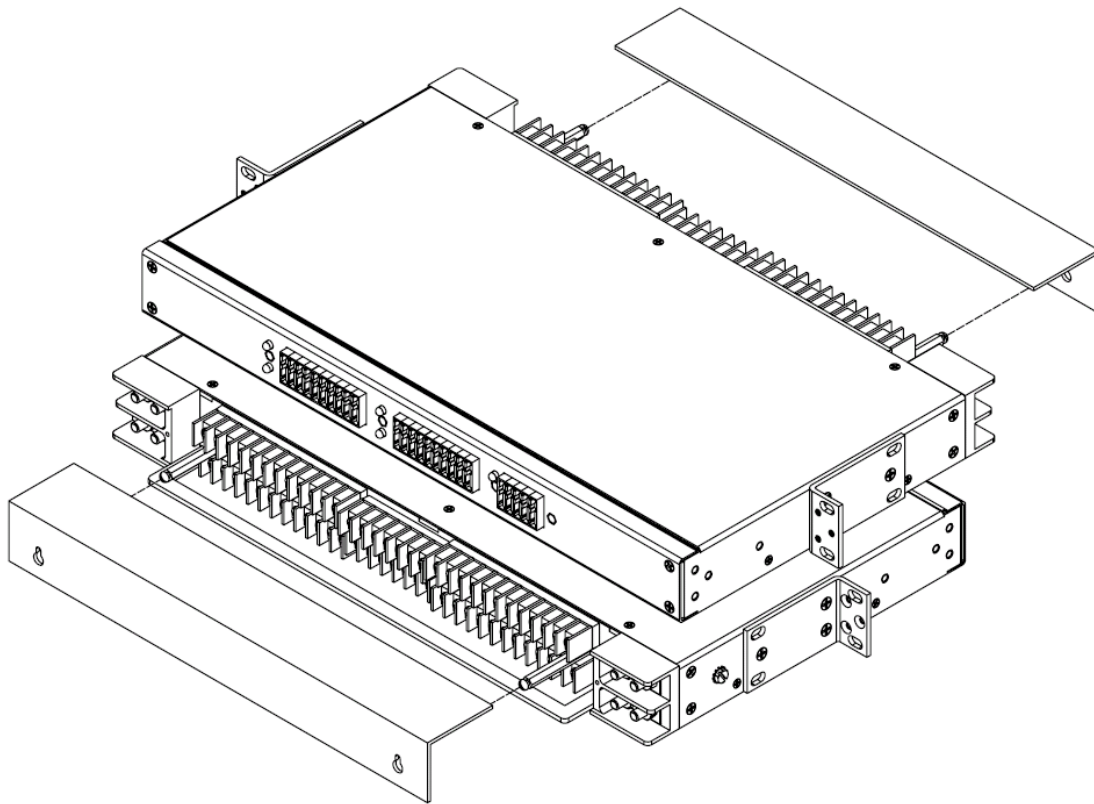

### FEATURES

- 2 isolated groups (busses) of 10 GMT fuses in each (15Amps/GMT position)
- Polarity insensitive (+/-24 or +/- 48 Vdc) battery voltage
- This panel can operate at 200 Amps of output current per panel (100 Amps per Bus)
- Barrier terminal strips for fused outputs and isolated returns (grounds)
- Three sets of Form C relay contacts are provided to extend alarms
- One set of alarm contacts for each; MAJOR Bus A, MAJOR Bus B and MINOR External Input Alarm
- MINOR External Input Alarm provided on the ground signal applied to the input pin
- Cable management bar (aka. towel bar) on rear panel included (flush style)
- Five spare fuse holders provided on the panel's faceplate
- Single 1.75" mounting height (single panel space)
- Two sets of mounting brackets are supplied (1" & 1-3/4" spacing), both sets of brackets are universal for 19" and 23" racks, with flush and offset mounting options
- NEBS level 3 certified, with zone 4 earthquake

## 1. GENERAL DESCRIPTION

1.1. The Newmar model FDP 1010 Fuse Panel provides up to 20 circuits for the distribution of DC power to equipment. Each of the 20 circuits is individually protected by a GMT style telecommunication fuse located on the panel's faceplate. Alarm circuits are provided to indicate and extend alarm conditions when faults occur. Normal Operation LEDs are provided to indicate the status of each bus in the panel.

1.2. Input wiring is connected to a high current, 2-hole lug input block located at the rear of the panel. Each group of fuses or bus has its own completely isolated inputs, allowing the distribution of two battery voltages through the same panel.

1.3. The power is distributed to the load side equipment through GMT style fuses. There are 10 fuses per fuse group and two groups per panel. Each fuse position is available for installer connection at the rear of the panel. A designation card is provided for keeping records of which position is connected to which equipment and what amperage is to be used.

1.4. Each panel is equipped with dummy fuses in all unused positions. The panel also can hold up to 5 spare fuses in the faceplate.

1.5. Alarm circuits are provided to alert service personnel of fault conditions. A fuse alarm is caused when any of the GMT distribution fuses opens. A red Fuse Alarm LED on the faceplate will illuminate and the green Normal Operation LED will extinguish to signal a fuse alarm and also the appropriate MAJOR relay contacts will change states. These fuse panels have common (C), normally open (NO) and normally closed (NC) terminals for both Major and Minor alarms. A Major alarm being a fuse or power failure in that bus and a Minor alarm being an external alarm. The external alarm is ground activated (20mA required to activate alarm.) Note, the use of the alarm contacts is optional, if you do not wish to extend the alarms, you don't have to do anything with the alarm pins.

The "Normal" condition of the relay exists when the panel is powered up without any blown fuses or externally activated alarms.

The red External Alarm LED on the units face plate will light when a ground is connected to the MINOR "Alarm In" terminal (20mA max. signal required to activate alarm.)

1.6. The N250120-N-L0521 Fuse Panels are made from 0.050" steel and painted black. Single rack height panels are shipped with two sets of universal brackets (1" & 1-3/4" spacing) that will fit both 19" and 23" wide racks and use only one 1.75" panel space. The panel has a clear L shaped lexan to protect the wiring connections on the back of the panel.

## 2. APPLICATION

2.1. The N250120-N-L0521 Fuse Panels are designed to be used in the distribution of DC power. They are rack mount panels that can provide fused DC power to up to 20 individual circuits, or 10 pieces of equipment, providing redundant battery feeds to each.

## 3. CIRCUIT DESCRIPTION

3.1. Power is connected to the fuse panel via \_ studs on 5/8" centers located at the rear of the panel (torque 5.5 ft-lbs.) These inputs are high current stud blocks that supply current to the fuse panel. Connect the battery return cable to the stud input that is labeled "RTN" and the Battery supply cable is connected to the terminals labeled "BAT".

3.2. Distribution of current from each bus is provided by GMT style fuses. Each bus has 10 fuse holders for distribution; the fuses are labeled F1 to F10 on each bus. Each fuse position is made available at the rear of the fuse panel. Maximum output current of each fused position is rated at 15 Amps, provided the maximum bus current or BDFB fuse is not exceeded (each bus is rated at 100Amps max.)

3.3. Fuse alarm circuitry provides 1 set of form "C" contacts (C, NO and NC) for each type of alarm (Major Bus A, Major Bus B and Minor-Ext). In the event of a fuse or external alarm, the proper relay will change states, providing a connection between the Normally Open "NO" and Common "C" terminals. The normally closed "NC" terminal will open to high impedance. The MINOR indicates an external ground input alarm (aka; bay or rack alarms.) Ground activates the external alarm input.

## 4. INSTALLATION

**Please read completely before beginning.**

**WARNING:** Installation should only be performed by an experienced Installer familiar with DC power distribution systems.

4.1. Unpack and inspect the Newmar Fuse Panel for possible damage incurred during shipping. If damage is found, file a claim immediately with the carrier, and notify Newmar.

4.2. Once the panel is unpacked, verify that there are two sets of mounting brackets (1" & 1-3/4" spacing). Adjust the position and orientation of the correct mounting brackets on the fuse panel, such that it will fit the rack you wish to mount the panel in. Single rack height panels have a universal bracket that allows the panel to be mounted on either 19" or 23" wide equipment racks and can be installed for flush mounting of the fuse panel, or for a 5" offset mounting.

4.3. Mount the panel on the equipment rack using the thread forming #12-24 rack mounting screws and tooth lock washers provided.

**WARNING:** For safety reasons all wiring should be done with the power source removed (when possible).

4.4. Remove the distribution fuse feeding the input cables that are to be connected to the new panel. Using input cables specified by the Job Engineer, hook up the input cables to the input terminal block on the fuse panel ("BAT" & "RTN" for each bus). Each high current input terminal uses a two hole compression lug (1/4" on 5/8", torque to 5.5 ft-lbs).

4.5. The battery outputs ("BAT") are available at the terminal blocks (#6 screw, up to 10awg fork) at the rear of the panel. Each fuse position is numbered and that circuit is available at the terminal block position with the same number.

4.6. All battery return ("RTN") connections are also terminated on barrier strips (#6 screw, up to 10awg fork). Note, these returns are isolated from the chassis frame.

4.7. This panel has MAJOR Bus A, MAJOR Bus B and MINOR External alarms. Each alarm has a common (C), normally open (NO) and normally closed (NC) alarm contact.

The Minor External Input Alarm is used for alarms that originate outside the panel (bay alarms). A ground signal is supplied from another device in the bay to activate this alarm.

In an alarm the "C" contact will short to the "NO" contact, and the "NC" will open. Connect the alarm connections as per your alarm system requirements. Newmar recommends you fuse the alarm battery supply (ABS) to 1A or less to protect the alarm wiring and circuitry.

4.8. **CHASSIS GROUND;** For safety reasons, and as recommended by NEBS, the chassis should be electrically connected to the rack ground. From step 4.3. the panel should already be ground to the rack via the #12-24 thread forming rack screws and outside tooth lock washers. In addition to grounding via the mounting brackets, it is recommended you ground the chassis using a ground cable and the #10 bolt and locks on side of chassis (#10 screw torque; 2ft-lbs or 2.7Nm).

4.9. Power up the panel by installing the distribution fuses supplying the panel. The panel should power up with the Normal Operation LED illuminated and without any red LEDs illuminated, and the relays should be in the "Normal" state ("C" connected to "NC").

4.10. If you wish to verify the fuse alarm circuit, you can insert a blown fuse into one of the empty fuse holders. The red Fuse Alarm LED should light and the Normal Operation LED should extinguish and the appropriate "MAJOR" alarm extension relay should change states to extend the alarm. If you wish to verify the externally activated alarm you can connect a GND to the External Alarm In, the External Alarm LED should light and the MINOR-external alarm extension relay should change states to provide the alarm extension.

4.11. Install panel output distribution fuses as required. Use the provided designation card to keep a record of which equipment is connected to which circuit and what the fuse rating is. Be careful not to overload the panel bus or BDFB fuse position rating supplying the panel.

**Note:** If you have any questions, suggestions, or problems, please don't hesitate to call Newmar Technical Support at (714) 751-0488, (email) [technicalservice@newmarpower.com](mailto:technicalservice@newmarpower.com) or contact us through the Internet at <http://www.newmartelecom.com>. Your input helps us in our ongoing product improvement process that benefits both of us. **Thank You.**

## 5. SPECIFICATIONS

5.1. Voltage -/+24 or -/+48 VDC Typical  
-/+22 to -/+58 VDC Max.  
5.2. Current/Fuse 15 Amps Maximum  
5.3. Current/Bus 100 Amps Max.

5.4. Current/Panel 200 Amps  
5.5. Output Fuse GMT Style Fuse Holders  
5.6. Output/Bus 10 Fuses (20 per panel)  
5.7. Output/Panel 2 Busses per Panel

5.8. Input Block	Two 1/2" Stud on 5/8 center	(excluding
5.9. Output Block	#22 AWG to 12 AWG wire Or fork/ring for #6 screw, 10awg forks/rings will work	brackets)
5.10. Alarm Block	#22 AWG to 12 AWG wire or fork/ring for # 6 screw.	5.14. Rack Mounting
5.11. Relay contacts	2 Amps/58Vdc max	19" and 23" Racks for 1" or 1-3/4" Panel Spaces
5.12. Relay activation	Gnd, 20mA max.	5.15. Weight
5.13. Dimensions	1_H, 17 W, 10_D	5.16. Operating Temp.
		Apprx. 8 Lbs -20° to +60°C (-5° to +140°F)
		5.17. Color
		Black

10 AWG fork/ring will work

### Compatible lugs for Input Block

2 hole compression lugs for 1/4" studs on 5/8" centers (torque 5.5ft-lbs), example;

Panduit® LCD2-14A 2awg wire  
LCD4-14A 4awg wire  
LCD6-14A 6awg wire  
LCD8-14A 8awg wire

**Output lugs** (locking fork recommended):  
Ring or fork for #6 screw (up to 10awg)

## 6. WARRANTY

This product manufactured for Newmar by Noran Tel is warranted to be free from defects from workmanship and components for a period of 2 years from the date of shipment. During this period any defective products shipped prepaid to Newmar will be repaired or replaced at our discretion and returned at no further cost to the customer. Newmar shall not be liable for any consequential or indirect damage of any type or nature, nor for any cost of reinstallation. Any product that has been subject to improper installation, unauthorized alteration, accident or misuse is rendered void of warranty.

Newmar also provides a repair service for products not covered by warranty. Charges will be levied for labor, components, and transportation.

To return a unit for repair contact the Newmar and obtain a **Return Material Authorization Number (RMA.)**

Be prepared to provide the following information:

1. Product Name
2. Product Model Number
3. Product Serial Number
4. Your contact person and phone number.
5. Your company name and return address

Package the unit in its original shipping carton or adequate substitute, along with a clear & complete description of the problem or defect. Clearly mark the outside of the carton with the Return Material Authorization Number and send the unit to the address shown below:

**NEWMAR**

**2911 W. Garry Ave  
Santa Ana, CA 92704**

**Phone:** (714) 751-0488

**Fax:** (714) 957-1621

**E-mail:** sales@newmarpower.com

**Internet:** <http://www.newmartelecom.com>

REV	Qty	Description or Release Note	EDN DDD APD	DATE
A		Original	347	

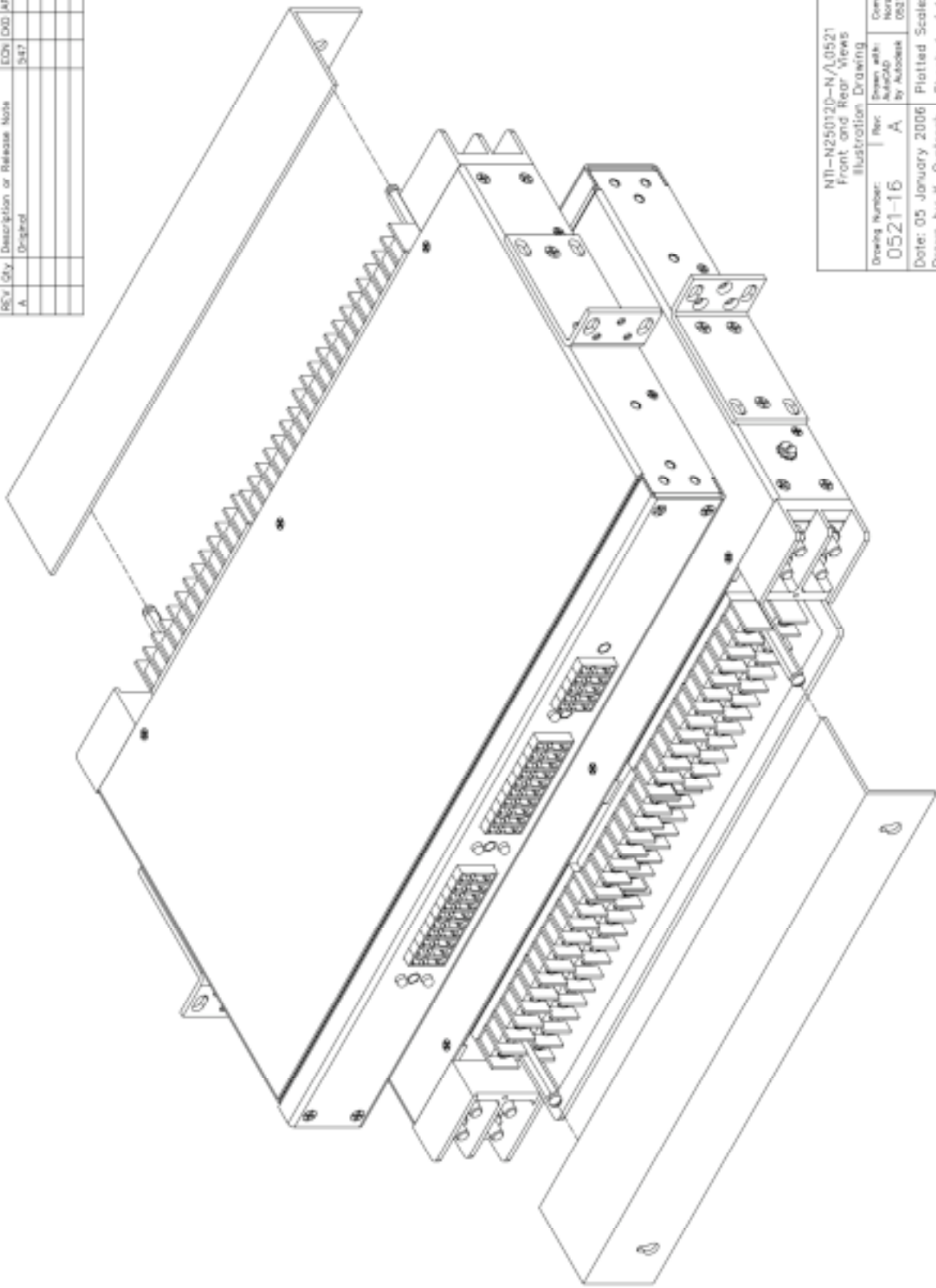

NI-N250120-N/A/0521 Front and Rear Views Illustration Drawing			
Drawing Number:	Rev:	Drawn with:	Computer File:
0521-16	A	Autocad by Autodesk	Noran 3d use only 0521-17a
Date: 05 January 2006	Plotted Scale: NTS		
Drawn by: K. Dyatreck		Sheet: 1 of 1	



